



# Vestil Manufacturing Company

2999 North Wayne Street, P.O. Box 507, Angola, IN 46703

Telephone: (260) 665-7586 -or- Toll Free (800) 348-0868

Fax: (260) 665-1339

[www.vestil.com](http://www.vestil.com)

[info@vestil.com](mailto:info@vestil.com)

## FMDL-Series Single & Double Eagle Beak Fork-Mounted Drum Lifters



FMDL-1 (Eagle Beak™)



FMDL-2 (Eagle Beak™)



FPDL-8-L (Base Engaging Plastic Barrel Handler)



FPDL-11-H (Top Engaging Plastic Barrel Handler)



DFDL-3 (Eagle Beak™, Top, & Base Engaging Barrel Handler)

### Receiving Instructions

After delivery, remove the packaging from the product. Inspect the product closely to determine whether it sustained damage during transport. If damage is discovered, record a complete description of it on the bill of lading. If the product is undamaged, discard the packaging.

**NOTE:** The end-user is solely responsible for confirming that product design, use, and maintenance comply with laws, regulations, codes, and mandatory standards applied where the product is used.

### Technical Service & Replacement Parts

For answers to questions not addressed in these instructions and to order replacement parts, labels, and accessories, call our Technical Service and Parts Department at (260) 665-7586. The department can also be contacted online at <https://www.vestil.com/page-parts-request.php>.

### Electronic copies of Instruction Manuals

Additional copies of this instruction manual may be downloaded from <https://www.vestil.com/page-manuals.php>.

TABLE OF CONTENTS		PAGE
Specifications.....		2
Signal Words.....		2
Safety Instructions.....		2
FMDL-1 Exploded View and Bill of Materials.....		3
FMDL-2 Exploded View and Bill of Materials.....		4
FPDL-11-H Exploded View and Bill of Materials.....		5
FPDL-8-L Exploded View and Bill of Materials.....		6
DFDL-3 Exploded View and Bill of Materials.....		7
Centers of Gravity Diagrams.....		8, 9, 10, 16, 17
Using the Lifter.....		11
Record of Satisfactory Condition.....		11 - 12
Inspections & Maintenance.....		12
Labeling Diagram.....		12
Optional Equipment.....		13, 14, 15, 16, 17
Limited Warranty.....		18

# SPECIFICATIONS

A specifications document for your drum carrier model is available on the Vestil website: [www.vestil.com](http://www.vestil.com). Specifications include dimensions, net weight, and capacity information. To access the appropriate specifications document, navigate to the appropriate webpage: a) FMDL-1 and FMDL-2 = <https://www.vestil.com/product.php?FID=774>; DFDL-3 = <https://www.vestil.com/product.php?FID=773>; FPDL = <https://www.vestil.com/product.php?FID=772>. Scroll the page to the "Product Specifications Table". Click the button in the "PDFs" column that looks like a pencil inside a blue box. A PDF file will open. This file is the specifications document. Print a copy of the document and keep it with your copy of this manual. The following is an exemplar specifications document for model FMDL-1.

## AUTOMATIC EAGLE BEAK DRUM LIFTER - FMDL-1

APPROX WEIGHT: 189.29 lbs.  
DOES NOT INCLUDE WEIGHT OF POWER OR PACKAGING!!!

\*\*\* ANY ADDITIONS, DELETIONS, OR OMISSIONS MUST BE CORRECTED ON THIS DRAWING AS THIS DRAWING WILL BE CONSIDERED ALL INCLUSIVE \*\*\*  
ALL GRAPHICS PROVIDED ARE FOR REFERENCE ONLY. IF CERTAIN DIMENSIONS ARE CRITICAL PLEASE VERIFY THOSE DIMENSIONS WITH YOUR SALESPERSON

40 7/8"
5 13/16"
31 1/4"
23 7/8"
8 13/16"
1 7/16"
29 3/4"
37 5/8"
42 5/8"
2 1/2"
7 1/2"
20 1/2"
28 1/2"

**STANDARD FEATURES**

- MODEL NUMBER IS FMDL-1
- CAPACITY IS 1,000 LBS (ONE DRUM)
- OVERALL LENGTH IS 42 5/8"
- OVERALL WIDTH IS 28 1/2"
- OVERALL HEIGHT IS 31 1/4"
- FOR USE WITH 30 & 55 GALLON PLASTIC, STEEL, & FIBER DRUMS
- DRUMS MAY HAVE OPEN OR CLOSED HEADS (LID INSTALLED AND SECURED)
- DRUMS MUST HAVE A TOP LIP STRONG ENOUGH TO SUPPORT THE WEIGHT OF THE DRUM
- INCLUDES SAFETY CHAIN & SNAP HOOK TO SECURE UNIT TO FORK TRUCK
- WELDED STEEL CONSTRUCTION
- TOUGH BAKED IN POWDER COATED BLUE FINISH
- USABLE FORK POCKETS ARE 7 1/2" W X 2 1/2" H
- FORK POCKETS ARE ON 20 1/2" CENTERS
- LOST LOAD IS 195 LBS. (APPROX)
- EFFECTIVE THICKNESS IS FORK LENGTH MINUS 29 3/4"
- SAFETY RATCHETING STRAP TO SECURE DRUM TO UNIT

**SPECIAL FEATURES**  
NONE

DIMENSION TOLERANCE ± 1/4"

I, THE UNDERSIGNED, AGREE THAT THE PRODUCT AS REPRESENTED SATISFIES DESIGN AND DIMENSION REQUIREMENTS. I ALSO ACKNOWLEDGE MY DUTY TO CONFIRM PRODUCT AND INSTALLATION COMPLIANCE WITH ALL APPLICABLE FEDERAL, STATE AND LOCAL REGULATIONS AND STANDARDS.

**ANY MODIFIED UNITS ARE NON-RETURNABLE**

[ ] As drawn [ ] As marked

Signed: \_\_\_\_\_ Date: \_\_\_\_\_

Printed Name: \_\_\_\_\_

**LEAD TIME WILL START UPON RECEIPT OF SIGNED APPROVAL DRAWING**

FOR INTERNAL USE ONLY PROJECT SIGN OFF	DISTRIBUTOR'S NAME: <b>VESTIL MANUFACTURING</b>		P.O.# X
SALES	DRAWN BY: WHR	DATE: 6/11/2012	W.O.# X
ENG.	REFERENCE: X	SCALE: 1:14	SALES: X
FAB.	QUOTED LEAD TIME: X	QUOTE # X	FILE NAME: 40-007-006
POWER			

NEVER EXCEED LOAD CENTER RATING PER FORK TRUCK MANUFACTURER'S GUIDELINES. DO NOT USE THIS FORK TRUCK ATTACHMENT IF LOAD WILL EXCEED FORK TRUCK MANUFACTURER'S LOAD CENTER RATING.

## SIGNAL WORDS

This manual uses SIGNAL WORDS to indicate the likelihood of personal injuries, as well as the probable seriousness of those injuries, if the product is misused in the ways described. Other signal words call attention to uses of the product likely cause property damage. The following are signal words used in this manual and their definitions.

<b>⚠ DANGER</b>	<b>Identifies a hazardous situation which, if not avoided, <u>WILL</u> result in DEATH or SERIOUS INJURY. Use of this signal word is limited to the most extreme situations.</b>
<b>⚠ WARNING</b>	<b>Identifies a hazardous situation which, if not avoided, COULD result in DEATH or SERIOUS INJURY.</b>
<b>⚠ CAUTION</b>	<b>Indicates a hazardous situation which, if not avoided, COULD result in MINOR or MODERATE injury.</b>
<b>NOTICE</b>	<b>Identifies practices likely to result in product/property damage, such as operation that might damage the product.</b>

## SAFETY INSTRUCTIONS

Vestil strives to identify foreseeable hazards associated with the use of its products. Material handling is dangerous and no manual can address every conceivable risk. The end-user must exercise sound judgment at all times. Acquire a copy of the latest version of ANSI B56.1 from [www.ITSDF.org](http://www.ITSDF.org). Apply all portions of Part II "For the User" that are relevant to front end attachments. The following recommendations complement the relevant provisions of B56.1.

### WARNING

Unsafe use of this product could result in serious personal injury or death.

- *Read and understand the entire manual before assembling, installing, using or servicing the product.* Read the manual to refresh your understanding of proper use and maintenance procedures. Maintenance personnel must read the manual before servicing the drum lifter.
- DO NOT exceed the maximum rated load. See Label 1153 on product; see [LABELING DIAGRAM](#), p. 9.
- DO NOT use this device with rough terrain lift trucks or telehandlers (boom trucks). ONLY use it with high lift fork trucks having a vertical mast and carriage.
- DO NOT mount the hopper on stackers or manually propelled lift trucks.
- DO NOT operate the truck carrying this device on unimproved surfaces. Only operate on concrete or asphalt.
- Mark your forklift truck to identify the drum lifter attachment and show the approximate weight of the truck and attachment combination at maximum elevation with load laterally centered. Capacity, operation, and maintenance instruction plates, tags, or decals must be changed accordingly.
- Inspect the drum lifter as instructed in the [INSPECTIONS & MAINTENANCE](#) section on p. 7-8. DO NOT use the device unless it is in satisfactory condition. If you observe any structural damage (for example, significant damage to either or both fork pockets, the safety chain/strap, or the drum-gripping mechanism), tag the unit "Out of Service" and report the damage to maintenance personnel. DO NOT use the lifter until it is restored to satisfactory condition.
- Inspect the drum before engaging it with the lifter. Make sure that the drum (particularly the rim and rolling hoops) is in good condition. DO NOT attempt to lift or transport a damaged drum with the lifter.
- Stay clear of the drum and lifter while the lifter is in use! No part of your body should ever be beneath any part of the elevated lifter or drum.
- ONLY use this device to move drums and only those drums that are compatible with your product, i.e. steel, plastic, and/or fiber. Compatibility information is provided with the [EXPLODED VIEWS](#) on pages 3-5.
- When transporting a drum, only raise it a few inches above the ground.
- Transport drums slowly. Avoid bumps, potholes, etc. when transporting a drum which could disrupt the lifter's grasp on the rim.
- Avoid sudden stops when transporting drums. Brake gradually. Sudden stops could cause the lifter to slide on the forks and could damage the safety strap, hook, and/or quick link. Turn slowly. Sharp, quick turns could disrupt the clamp on the drum and damage the lifter.
- DO NOT modify the lifter in any way. **Unapproved modifications automatically void the LIMITED WARRANTY (see p. 10) and might make the product unsafe to use.**
- DO NOT use the lifter UNLESS all labels are in place, readable, and undamaged. See [LABELING DIAGRAM](#) on p. 9.
- For the Eagle Beak™ mechanism to work properly, the drum plus contents must weigh at least 50lb. (~22.7kg).
- The chain is an essential safety-enhancing feature. Wrap the chain around the fork carriage and fasten the free end to the chain or quick link **with no slack**.

### FMDL-1 EXPLODED VIEW AND BILL OF MATERIALS (40-006-006)

[NOTE: Part no. 40-514-022 is the "Drum gripper assembly" comprised of items 9-26 (shaded).]

Item	Part No.	Description	Qty.	Item	Part No.	Description	Qty.
1	40-514-008	WELDMENT, FRAME	1	14	40-514-011	WELDMENT, FRAME	1
2	40-514-022	ASSEMBLY, FRAME	1	15	40-612-006	WELDMENT, PIN, SADDLE RETAINER	1
3	65125	COTTER PIN Z PLATED, 3/16" x 1 1/2"	1	16	40-612-004	PIN,CLEVIS	1
4	99-112-004	PIN, SELF LOCKING QUICK RELEASE, GENERAL	1	17	45286	#11 HITCH PIN CLIP, Ø1/8" X 2 5/8 LG	3
5	09-145-018	CHAIN, 5/16" x 56" LG	1	18	21-112-003	PIN, Ø1/2 X 1-15/16 LG RETAINING CLEVIS	2
6	08-145-041	SPECIALTY HARDWARE, SNAP HOOK, Ø5/16	1	19	28-112-031	Ø3/4 x 4 1/2 LG CLEVIS PIN	2
7	33-112-023	PIN, CLEVIS	1	20	40-014-029	FRAME, BAR, FORMED	1
8	40-145-008	STRAP WITH RATCHET, 6' LONG, 2 HOOKS	1	21	11003	HEX BOLT, GRADE A, ZINC PLATED, 1/4-20 X 3/4"	2
9	40-514-006	WELDMENT, FRAME	1	22	37018	NYLON LOCK NUT, GRADE 2, ZINC FINISH, 1/4"-20	2
10	40-014-054	FRAME, CASTING	1	23	65078	EXTENDED PRONG COTTER PIN, ZINC FINISH, 1/8" x 1 1/2"	3
11	40-014-093	FRAME, DRUM GRIP, CASTING	1	24	40-146-001	SPRING, TENSION	1
12	40-016-052	BRACKET, CASTING	1	25	40-112-026	CLEVIS PIN, Ø5/8" x 2 1/2"	1
13	40-016-053	BRACKET, CASTING, FMDL SERIES	1	26	33018	USS FLAT WASHER, Z PLATED, Ø 3/4"	1

**NOTE:** In order for the Eagle Beak™ mechanism to work properly, the drum and its contents must weigh AT LEAST 50 lb. (~22.7kg).

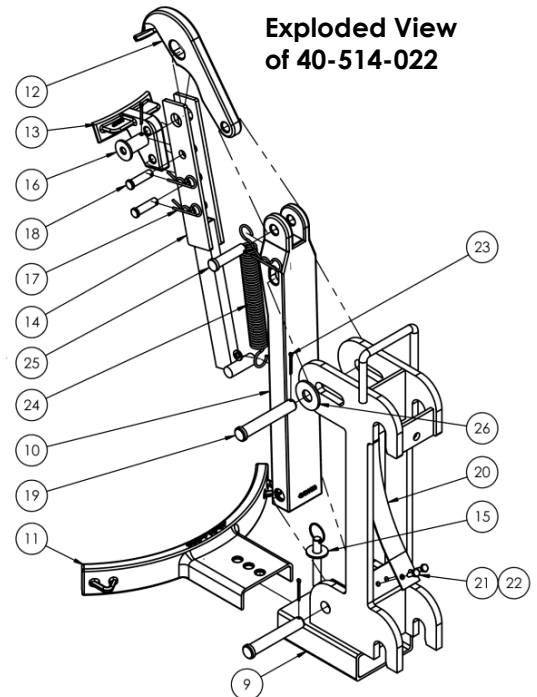
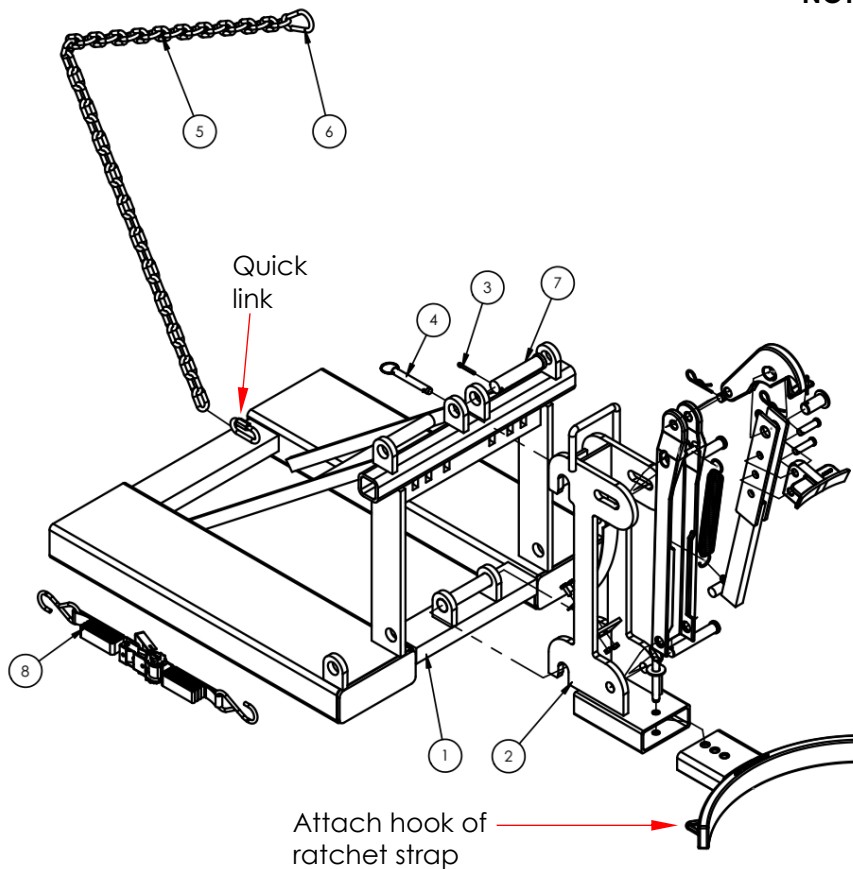

### FMDL-2 EXPLODED VIEW AND BILL OF MATERIALS (40-006-004)

**NOTE 1:** "Drum gripper assembly" comprised of items 10-27 (shaded).

**NOTE 2:** In order for the Eagle Beak™ mechanism to work properly, each drum and its contents must weigh AT LEAST 50 lb.

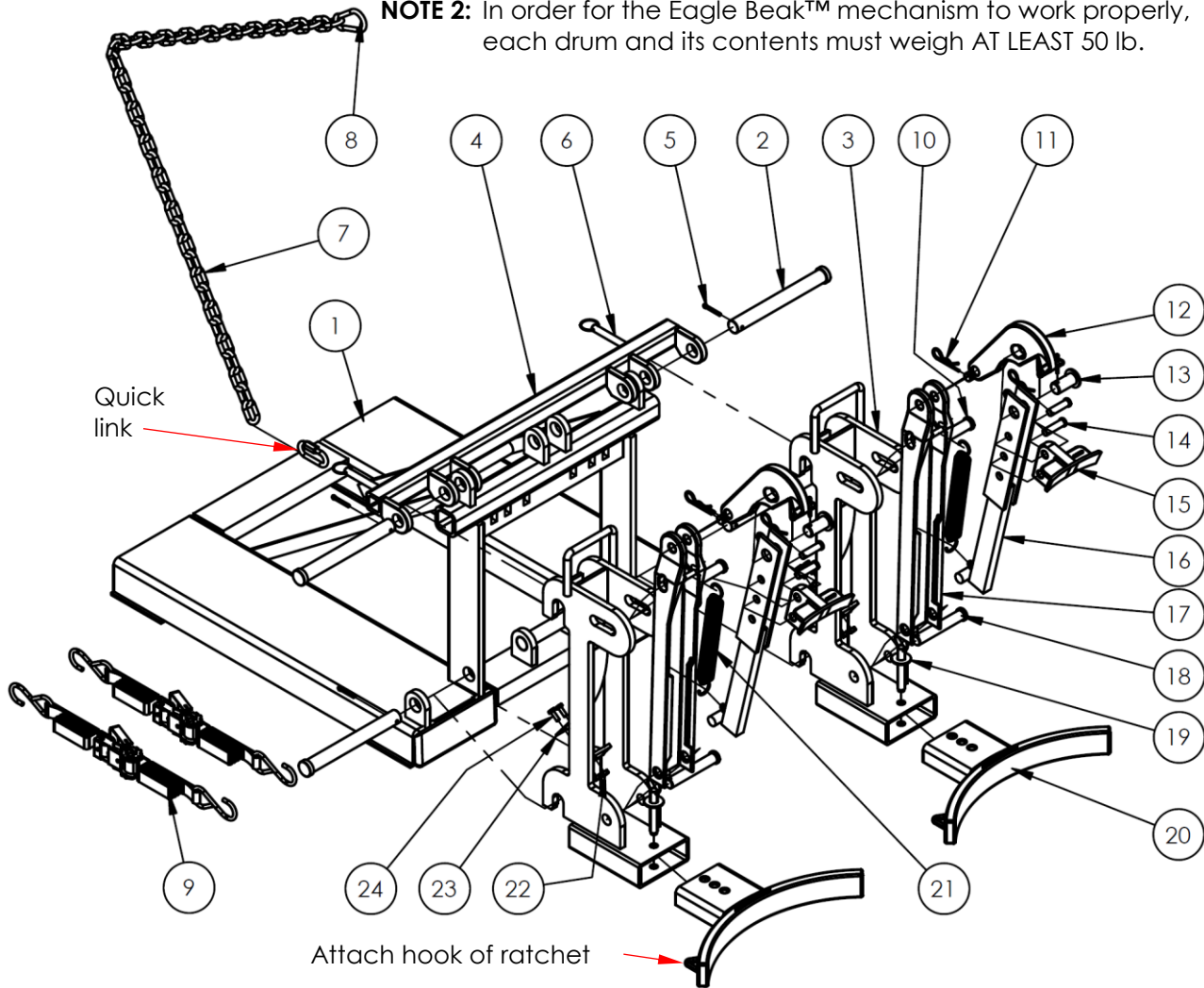

Item	Part No.	Description	Qty.	Item	Part No.	Description	Qty.
1	40-514-008	Weldment, frame	1	13	40-612-004	Pin, clevis, 7/8" x 1 3/4" long, with washer	2
2	40-112-001	Pin, main, clevis,	4	14	21-112-003	Pin, clevis, 1/2" x 1 3/4" long	4
3	40-514-022	Drum gripper assembly	2	15	40-016-053	Lower jaw, Eagle Beak™	2
4	40-516-008	Weldment, bracket, mounting bar	1	16	40-514-011	Weldment, pin bracket	2
5	65125	Cotter pin, zinc plated, 3/16" x 1 1/2"	4	17	40-014-054	Weldment, channel	2
6	99-112-004	Pin, self-locking quick release	2	18	28-112-031	Pin, clevis, 3/4" x 4 1/4"	4
7	09-145-018	5/16" chain 56" long	1	19	40-612-006	Weldment, pin, cradle retainer	2
8	40-145-008	Specialty hardware, snap hook, 5/16"	1	20	40-014-093	Drum cradle	2
9	40-145-008	Strap with ratchet, 6' long, 2 hooks	1	21	40-146-001	Spring, tension, 6 1/2"	2
10	28-112-031	Pin, clevis, 3/4" x 4 1/4"	2	22	37018	Lock nut, 1/4" - 20	4
11	45286	Clip, hitch pin, 1/8" x 2 5/8"	6	23	40-014-029	Frame, bar, formed	2
12	40-016-052	Upper jaw, Eagle Beak™	2	24	11003	Bolt, hex head, 1/4" - 20 x 3/4"	4

### FPDL-11-H EXPLODED VIEW AND BILL OF MATERIALS (40-006-007)

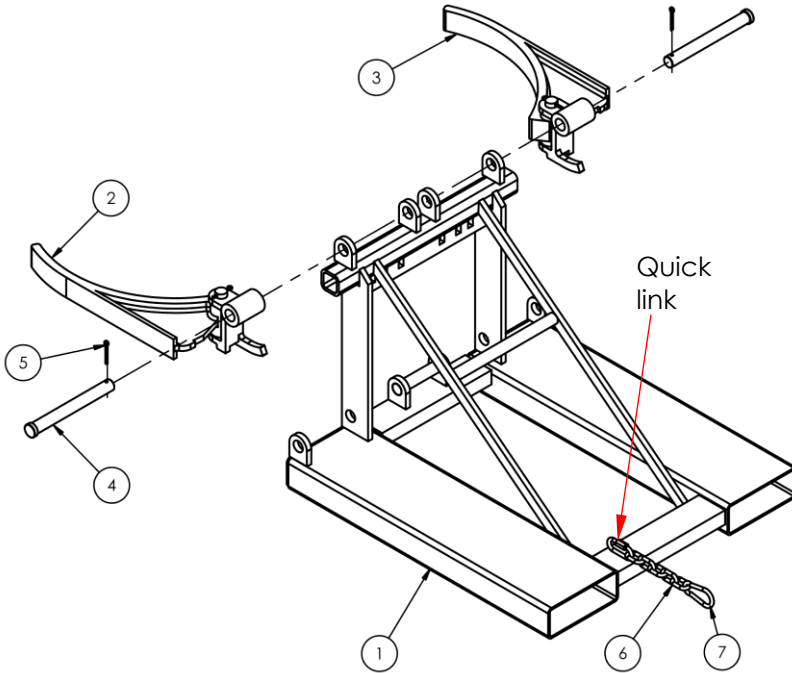

Item	Part No.	Description	Qty.
1	40-514-008	WELDMENT, FRAME	1
2	40-514-022	ASSEMBLY, FRAME	1
3	65125	COTTER PIN Z PLATED, 3/16" x 1 1/2"	1
4	99-112-004	PIN, SELF LOCKING QUICK RELEASE, GENERAL	1
5	09-145-018	CHAIN, 5/16" x 56" LG	1
6	08-145-041	SPECIALTY HARDWARE, SNAP HOOK, Ø5/16	1
7	33-112-023	PIN, CLEVIS	1
8	40-145-008	STRAP WITH RATCHET, 6' LONG, 2 HOOKS	1

### FPDL-8-L EXPLODED VIEW AND BILL OF MATERIALS (40-006-008)

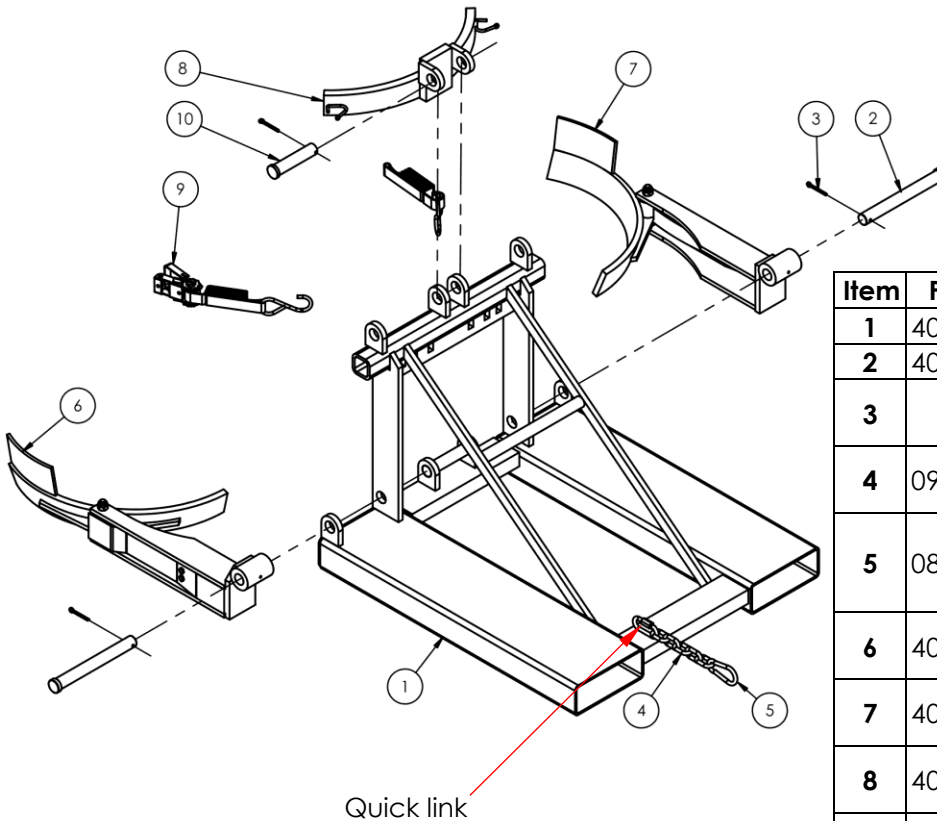

Item	Part No.	Description	Qty.
1	40-514-008	WELDMENT, FRAME	1
2	40-112-001	PIN, MAIN, CLEVIS	2
3	65127	COTTER PIN Z PLATED, 3/16 x 2	3
4	09-145-018	CHAIN, 5/16" x 56" LG	1
5	08-145-041	SPECIALTY HARDWARE, SNAP HOOK, Ø5/16	1
6	40-514-012	ASSEMBLY, FRAME, DRUM GRIPPER L.S.	1
7	40-514-013	ASSEMBLY, FRAME, DRUM GRIPPER R.S.	1
8	40-514-021	WELDMENT, FRAME, DRUM SUPPORT	1
9	40-145-008	STRAP WITH RATCHET, 6' LONG, 2 HOOKS	1
10	33-112-023	PIN, CLEVIS	1

### DFDL-3 PARTS DIAGRAMS AND BILL OF MATERIALS (40-006-005)

**NOTE:** In order for the Eagle Beak™ mechanism to work properly, the drum and its contents must weigh AT LEAST 50 lb. (~22.7kg).

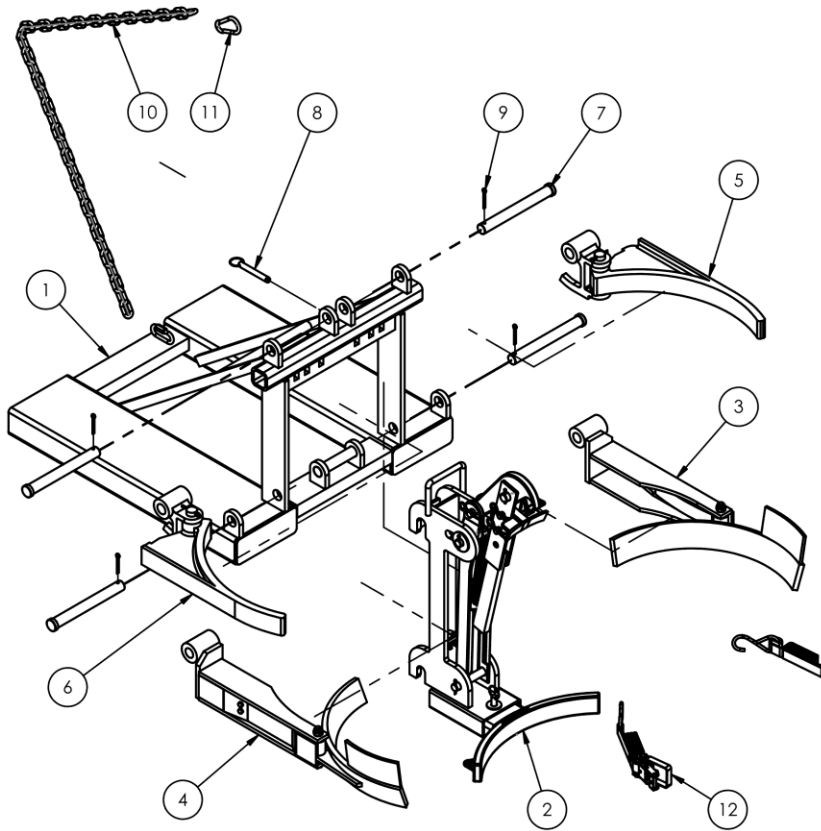

Item	Part No.	Description	Qty.
1	40-514-008	WELDMENT, FRAME	1
2	40-514-022	ASSEMBLY, FRAME	1
3	40-514-012	ASSEMBLY, FRAME, DRUM GRIPPER L.S.	1
4	40-514-013	ASSEMBLY, FRAME, DRUM GRIPPER R.S.	1
5	40-514-014	ASSEMBLY, FRAME, ARM LEFT	1
6	40-514-015	ASSEMBLY, FRAME, ARM RIGHT	1
7	40-112-001	PIN, MAIN, CLEVIS	4
8	99-112-004	PIN, SELF LOCKING QUICK RELEASE, GENERAL	1
9	65127	COTTER PIN Z PLATED, 3/16 x 2	4
10	09-145-018	CHAIN, 5/16" x 56" LG	1
11	08-145-041	SPECIALTY HARDWARE, SNAP HOOK, Ø5/16	1
12	40-145-008	STRAP WITH RATCHET, 6' LONG, 2 HOOKS	1

### EXPLODED VIEW OF ITEM 2, PART NO. 40-514-022 "Eagle Beak" drum gripper

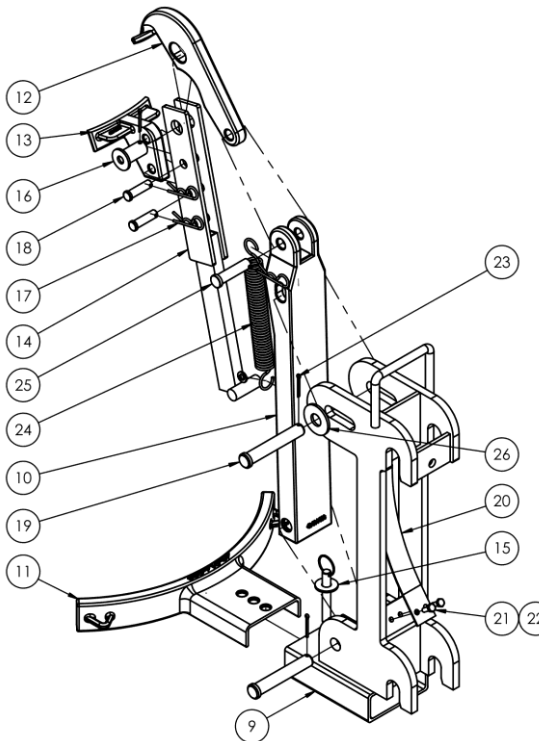

ITEM	PART NO.	DESCRIPTION	QTY.
13	40-514-006	WELDMENT, FRAME	1
14	40-014-054	FRAME, CASTING	1
15	40-014-093	FRAME, DRUM GRIP, CASTING	1
16	40-016-052	BRACKET, CASTING	1
17	40-016-053	BRACKET, CASTING, FMDL SERIES	1
18	40-514-011	WELDMENT, FRAME	1
19	40-612-006	WELDMENT, PIN, SADDLE RETAINER	1
20	40-612-004	PIN, CLEVIS	1
21	45286	#11 HITCH PIN CLIP, Ø1/8" X 2 5/8 LG	3
22	21-112-003	PIN, Ø1/2 X 1-15/16 LG RETAINING CLEVIS	2
23	28-112-031	Ø3/4 x 4 1/2 LG CLEVIS PIN	2
24	40-014-029	FRAME, BAR, FORMED	1
25	11003	HEX BOLT, GRADE A, ZINC PLATED, 1/4-20 X 3/4"	2
26	37018	NYLON LOCK NUT, GRADE 2, ZINC FINISH, 1/4"-20	2
27	65078	EXTENDED PRONG COTTER PIN, ZINC FINISH, 1/8" x 1 1/2"	3
28	40-146-001	SPRING, TENSION	1
29	40-112-026	CLEVIS PIN, Ø5/8" x 2 1/2"	1
30	33018	USS FLAT WASHER, Z PLATED, Ø 3/4"	1

**FMDL-1 CENTER OF GRAVITY DIAGRAMS (40-007-006)**

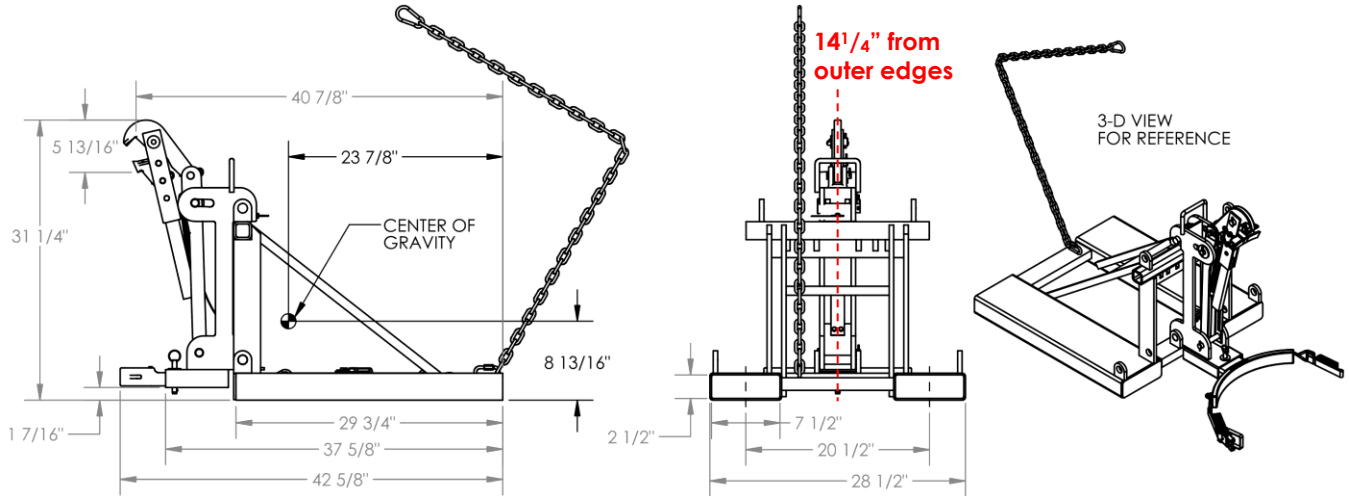

**Horizontal center of gravity (HCG):** 23<sup>7</sup>/<sub>8</sub> inches (~60.6 cm) from the open ends of the fork pockets and 14<sup>1</sup>/<sub>2</sub>" inches from the outermost edges of the fork pockets (dotted line in middle graphic above).

**Vertical center of gravity:** 8<sup>13</sup>/<sub>16</sub> inches (~22.4 cm) from the top of the fork pockets.

**FMDL-2 CENTER OF GRAVITY DIAGRAMS (40-007-004)**

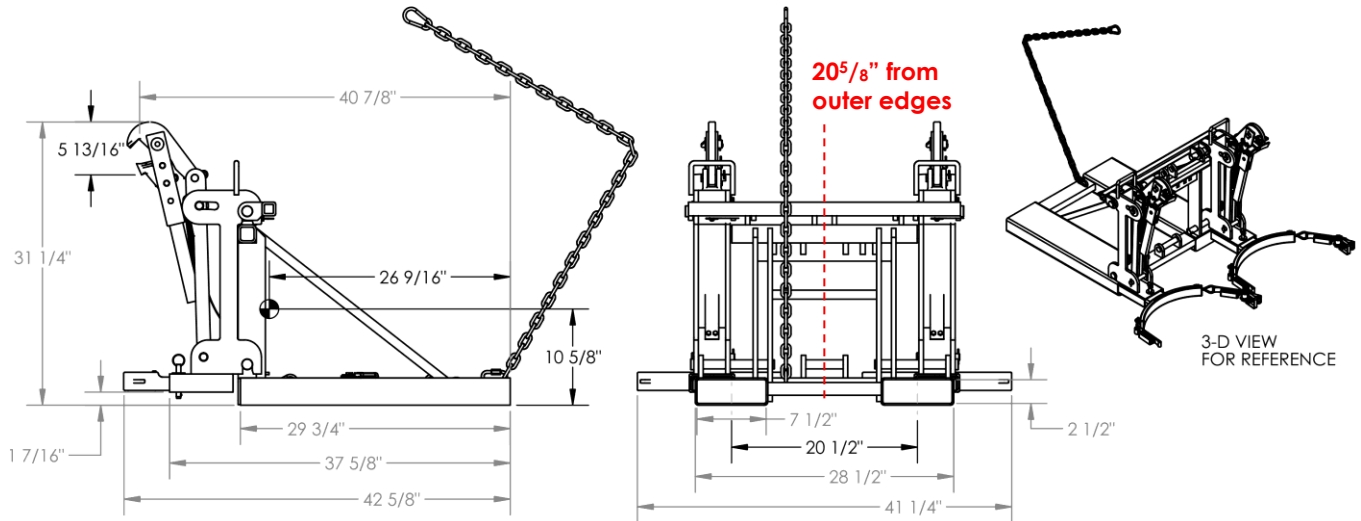

Horizontal center of gravity (HCG): 26<sup>9</sup>/<sub>16</sub> inches (~67.5 cm) from the open ends of the fork pockets and 20<sup>5</sup>/<sub>8</sub>" (~52.4 cm) from the outermost edges of the drum lifter (dotted line in middle graphic above).

Vertical center of gravity: 10<sup>5</sup>/<sub>8</sub> inches (~27.0 cm) from the top of the fork pockets.



**FPDL-8-L CENTER OF GRAVITY DIAGRAMS (40-007-008)**

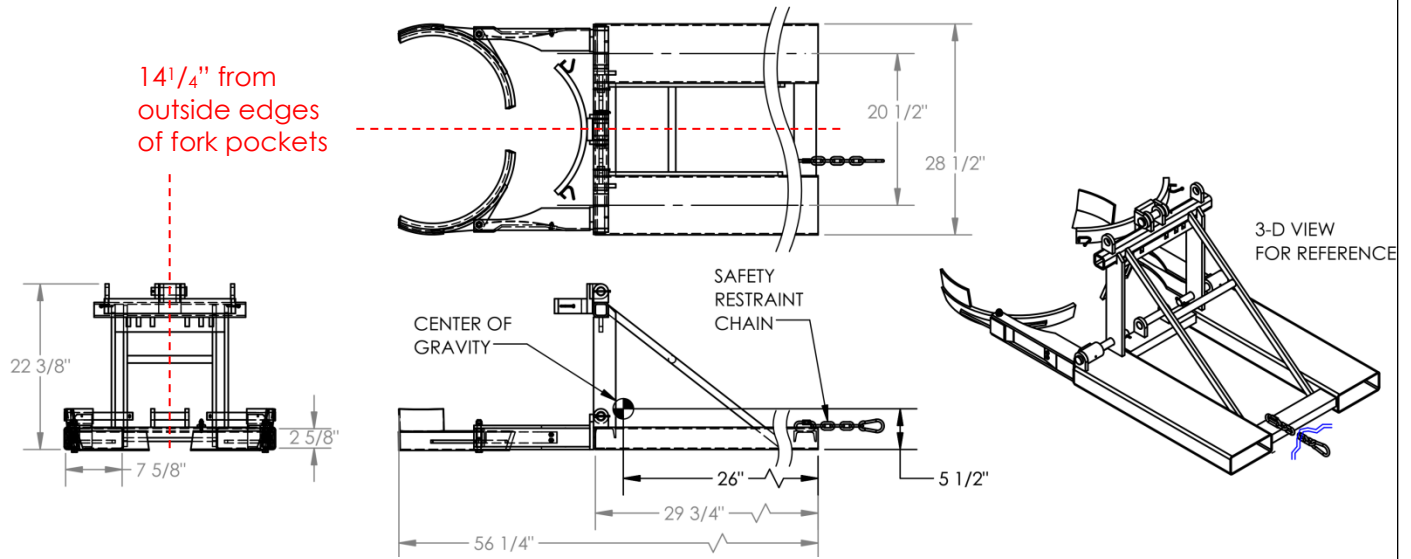

Horizontal center of gravity (HCG):

- 26 inches (~66.0cm) from the open ends of the fork pockets; and
- 14 1/4 inches (~36.2cm) from the outer edge of each fork pocket (halfway between the fork pockets).

Vertical center of gravity:

- 5 1/2 inches (~14.0cm) from the bottom of the fork pockets.

**FPDL-11-H CENTER OF GRAVITY DIAGRAMS (40-007-007)**

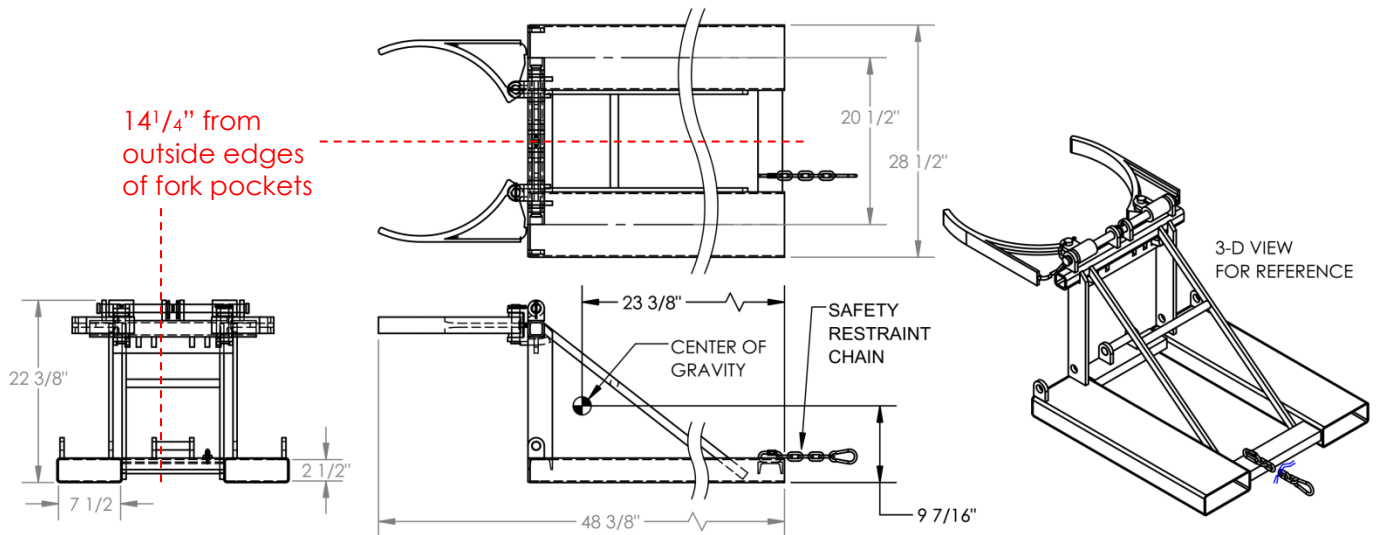

Horizontal center of gravity (HCG):

- 23 3/8 inches (~59.4cm) from the open ends of the fork pockets; and
- 14 1/4 inches (~36.2cm) from the outer edge of each fork pocket (halfway between the fork pockets).

Vertical center of gravity:

- 9 7/16 inches (~24.0cm) from the bottom of the fork pockets.

**DFDL EAGLE BEAK CENTER OF GRAVITY DIAGRAM (40-007-005)**

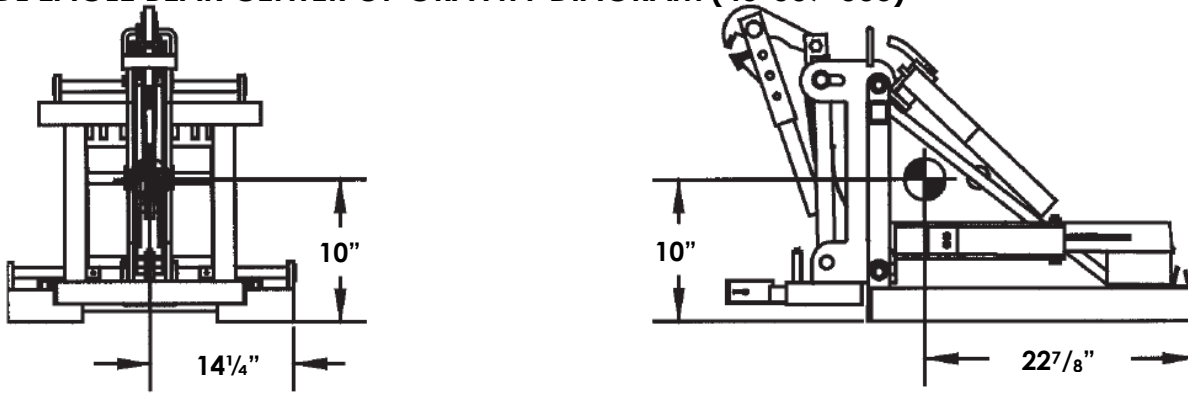

Horizontal center of gravity (HCG):

- 22<sup>7</sup>/<sub>8</sub> inches (~58.1cm) from the open ends of the fork pockets; and
- 14<sup>1</sup>/<sub>4</sub> inches (~36.2cm) from the outer edge of each fork pocket (halfway between the fork pockets).

Vertical center of gravity:

- 10 inches (~25.4cm) from the bottom of the fork pockets.

**DFDL-3 LOWER DRUM GRIPPING ARMS CENTER OF GRAVITY DIAGRAM**

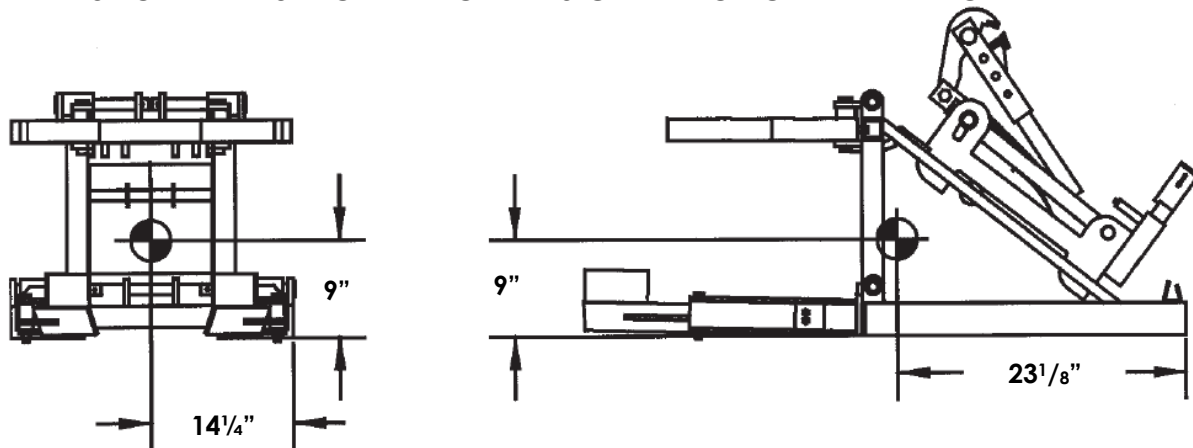

Horizontal center of gravity (HCG):

- 23<sup>1</sup>/<sub>8</sub> inches (~58.7cm) from the open ends of the fork pockets; and
- 14<sup>1</sup>/<sub>4</sub> inches (~36.2cm) from the outer edge of each fork pocket (halfway between the fork pockets).

Vertical center of gravity:

- 9 inches (~22.9cm) from the bottom of the fork pockets

**DFDL-3 UPPER DRUM GRIPPING ARMS CENTER OF GRAVITY DIAGRAM**

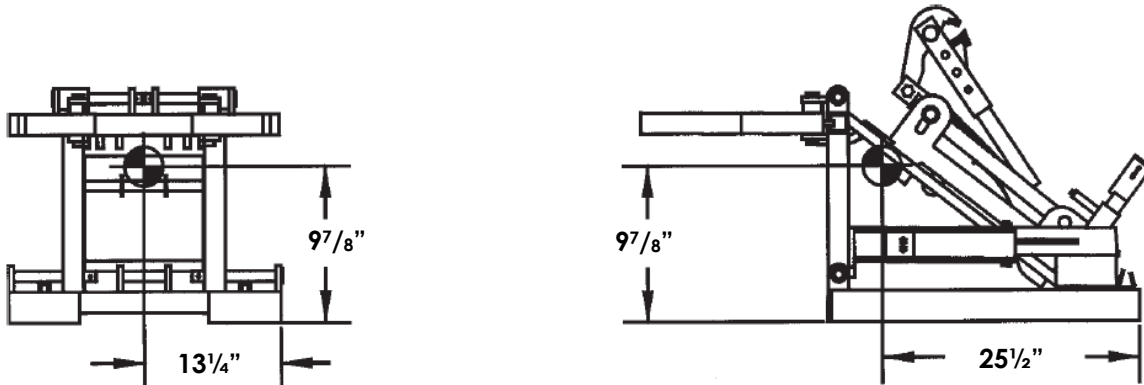

Horizontal center of gravity (HCG):

- 25<sup>1</sup>/<sub>2</sub> inches (~64.8cm) from the open ends of the fork pockets; and
- 13<sup>1</sup>/<sub>4</sub> inches (~33.7cm) from the outer edge of each fork pocket (halfway between the fork pockets).

Vertical center of gravity:

- 11 inches (~28cm) from the bottom of the fork pockets

## USING THE LIFTER

**Step 1:** Adjust the positions of the forks on the carriage (of your lift truck) to align with the fork pockets (of the lifter).

**Step 2:** Mount the drum lifter on the forks of your lift truck by slowly driving forward until the forks contact the ends of the pockets.

**Step 3:** Attach the safety chain to the fork carriage. Wrap the chain around the carriage. Fasten the snap hook to the chain or quick link (see exploded parts diagrams) **without slack**. The chain must not be able to disconnect from the carriage during use, i.e. slide off of the carriage.

Model	Description	Compatible Drums
FMDL-1	Eagle Beak™ single drum lifter	<ul style="list-style-type: none"> <li>• 30 &amp; 55 gallon</li> <li>• Open &amp; closed head</li> <li>• Steel, plastic, &amp; fiber</li> </ul>
FMDL-2	Eagle Beak™ two drum lifter	<ul style="list-style-type: none"> <li>• 30 &amp; 55 gallon</li> <li>• Open &amp; closed head</li> <li>• Steel, plastic, &amp; fiber</li> </ul>
DFDL-3	Deluxe 3-mode drum lifter: Eagle beak, Bottom grip & Top grip	<ul style="list-style-type: none"> <li>• 30 &amp; 55 gallon</li> <li>• Open &amp; closed head</li> <li>• Steel, plastic, &amp; fiber</li> </ul>
FPDL-8-L "L" = low attachment	Bottom gripping drum handler for oddly shaped plastic drums	<ul style="list-style-type: none"> <li>• 55 gallon</li> <li>• Open &amp; closed head</li> <li>• Plastic</li> </ul>
FPDL-11-H "H" = high attachment	Top gripping drum handler for oddly shaped plastic drums	<ul style="list-style-type: none"> <li>• 30 &amp; 55 gallon</li> <li>• Closed head plastic</li> <li>• Also ok for steel &amp; fiber</li> </ul>

### ⚠ WARNING

Unsafe use could result in death or serious injury.

- The chain is an essential safety-enhancing feature. Wrap the chain around the carriage and fasten the free end to the chain **with no slack**. *The chain will not prevent the drum lifter from sliding off of the forks if it is improperly connected to the fork carriage.*

- Using this device affects lift truck center of gravity. Before using the lifter, US Federal regulation 29 CFR 1910.178 requires you to contact the manufacturer of your lift truck and request: 1) Written approval; 2) Markings for the lift truck that identify the attachment and provide the approximate weight of truck and attachment at maximum elevation with load laterally-centered.

**DO NOT** use this lifter **UNTIL your** lift truck is marked with corrected capacity tags.

### FMDL-1 and FMDL-2 Eagle Beak™ and DFDL-3 models

**NOTE:** In order for the Eagle Beak™ mechanism to work properly, the drum and its contents must weigh AT LEAST 50 lbs. (~22.7kg).

**Step 4 Engage the selected drum with the lifter:** Raise the forks a few inches off of the ground/floor, and tilt the mast of your fork truck forward. Drive slowly towards the selected drum until the lower jaw of the Eagle Beak™ (items no. 12 & 13, [p. 4](#)) contacts the side of the drum directly beneath the lip of the drum.

**Step 5 Grasp the lip of the drum:** Slowly raise the forks until the upper jaw engages the top of the drum lip. Continue to raise the forks until the drum is elevated a few inches above the floor/ground. Attach one end of the ratchet strap to a loop on the drum saddle (Item 11, [p. 4](#)). Attach the other end of the ratchet strap to the loop on the other side of the saddle; then work the ratchet mechanism until the strap is tight.

**Step 6 Transport the drum:** Straighten the mast and transport the drum to the desired unloading location. Raise the forks when/as required by conditions along the travel path.

**Step 7 Release the drum:** Lower the forks until the drum is just a few inches above the floor, and then remove the ratchet strap. Tilt the fork truck mast forward. Slowly lower the forks until the Eagle Beak™ disengages the lip of the drum and the drum is fully supported by the floor/ground.

### FPDL-11-H and DFDL-3 models

**Step 4 Position the fork lift and drum lifter:** Raise the forks and adjust the location of the fork lift to position the drum grippers above the top of the drum. Tilt the mast forward, i.e. point the forks toward the floor.

**Step 5 Position drum grippers:** Lower the forks; the drum grippers will slide over the lip of the drum. Position the grippers below the lip or the middle rim as desired.

**Step 6 Transport the drum:** Straighten the mast and raise the forks until the gripper engages the lip or rim, and then slowly raise the forks until the drum is elevated a few inches above the floor. Tilt the mast back; then transport the drum to the desired location.

**Step 7 Release the drum:** First tilt the mast forward and then slowly lower the forks until the drum is fully supported by the floor. To finish disengaging the drum, back the fork truck away from it.

**FPDL-8-L and DFDL-3 models**

Step 4 Position fork lift and drum lifter: Adjust the mast position so that the drum grippers are parallel to the ground. Slightly elevate the forks above the floor.

Step 5 Prepare to engage the drum: Adjust the position of the fork truck to center the drum lifter on the drum; then drive forward until the side of the drum contacts the upper side wall support weldment. See Item no. 8, [p. 6](#).

Step 6 Transport drum: Raise the forks until the lower drum gripper weldments (item nos. 6 & 7, [p. 6](#); items no. 5 & 6 on [p. 7](#)) engage the base of the drum. Raise the drum a few inches above the ground; secure it to the lifter by attaching the ratchet strap to the loops on the side wall support (Item no. 8, [p. 6](#)); then transport it to the desired unloading point.

Step 7 Release the drum: First tilt the mast forward; then slowly lower the forks until the drum is fully supported by the ground/floor. Slowly back the fork lift away from the drum until the drum and lifter disengage.

**RECORD OF SATISFACTORY CONDITION (THE RECORD™)**

Before putting the drum lifter into service, record its condition. Thoroughly photograph the unit from multiple angles. Take close-range photographs of the drum gripping mechanism, the labels, all pivot points, the drum saddle(s), the safety chain and snap hook, and fork/tine locks (if applicable). Use the lifter to lift a drum. Describe how the drum grasping mechanism engages the drum. Describe all sounds produced by the lifter under load. Collate the photographs and writings into a file. Mark the file appropriately to identify it. Compare the results of all inspections to this record to determine whether the lifter is in satisfactory condition. Do not use the lifter unless it is in satisfactory condition. Purely cosmetic changes, like damaged paint or powdercoat are not changes from satisfactory condition. However, touchup paint should be applied to all affected areas as soon as the finish is damaged.

**INSPECTIONS & MAINTENANCE****NOTICE**

Proper use, maintenance, and storage are essential for this product to function properly.

- Inspect the unit as instructed.
- Use this front end attachment as recommended in the current revision of ANSI/ITSDF B56.1 and all instructions in this manual.
- Store the unit in a dry location.

Inspection procedures are included in the most current revision of ANSI/ITSDF B56.1. As stated in the [NATIONAL STANDARDS](#) section on p. 6, Vestil recommends that you acquire a copy of the most recent revision of this standard. Apply all use and maintenance/care instructions in the standard. Vestil also recommends that you contact your local occupational health and safety authority to determine if any state or local laws, regulations, codes, ordinances, etc. apply inspection requirements where the carrier is used.

Inspections and all necessary repairs should be performed by qualified persons. Compare the results of each inspection to the [RECORD OF SATISFACTORY CONDITION](#). Do not use the crane unless every part is in satisfactory condition. Purely cosmetic changes, like damaged paint/powdercoat, are not changes from satisfactory condition. However, touchup paint must be applied as soon as damage occurs to prevent rust from forming. Rust could cause the affected part to become unsound, which could make the carrier unsafe to use.

**DON'T GUESS!** If you have any questions about the condition of your product, contact the [TECHNICAL SERVICE](#) department. The phone number is provided on the cover page of this manual. Never make temporary repairs of damaged or missing parts. Only use manufacturer-approved replacement parts to restore the crane to satisfactory condition.

**INSPECTIONS**

**A.** Before each use inspect the following components:

1. Carriage strap/chain and snap hook: Confirm that the latch of the snap hook automatically closes. Examine the strap for cuts, tears, and areas of significant wear. Examine the snap hook (at the free end of the strap). It must not be bent or cracked or twisted.
2. Labels: Labels must be easily readable, undamaged, and be located where indicated in the [LABELING DIAGRAM](#) on p. 9. If a label is damaged, unreadable, or missing, contact the [TECHNICAL SERVICE AND REPLACEMENT PARTS DEPARTMENT](#) to order a replacement.

- B. Periodic Inspections:** At least once every 2 weeks inspect the carrier to confirm satisfactory condition. Do not return it to service unless it is in satisfactory condition.
1. Fasteners (hardware) and hand chain: Examine all bolts, nuts, washers, pins, the quick link, and snap hooks. Tighten loose fasteners. Replace locking fasteners with new fasteners
  2. Fork pockets: Confirm that each pocket is structurally sound. In particular, examine the underside of the each pocket for rust and corrosion.
  3. Welds: Make sure that all welds are intact. Check welds & the metal surrounding welds for damage.
  4. Gripper arms and hinge castings: Confirm that both arms and hinge castings are not cracked or warped. Hinge castings should rotate smoothly to allow the arms to fold onto the frame for compact storage.
  5. Safety strap, quick link, and hook (attached to the free end of the safety chain): Confirm that the quick link is undamaged and welded securely to the frame. The snap hook should not be bent, stretched, cracked, or otherwise damaged. Check the strap for cuts, tears, etc. If your unit is equipped with a safety chain instead of a strap, check the chain links for breaks, cracks, bends, elongations, etc.
  6. Pivot points/ hinges: Confirm that gripper arms pivot normally and/or that hinges operate normally. Check pivot points and hinges for significant wear. Lubricate the hinges. Lubrication might have to be applied more frequently under heavy usage conditions.
  7. Frame: The structure should be clean, square and rigid, and free of rust and corrosion. Clean the frame. Examine it for severe wear, rust, and other forms of damage.

## MAINTENANCE

**Step 1:** Tag the unit "Out of Service."

**Step 2:** Remove any dirt or other matter from all surfaces.

**Step 3:** Conduct a "Periodic" inspection. If deformity, corrosion, rusting, or excessive wear of structural members is found, permanently remove the unit from service.

**Step 4:** Perform all necessary adjustments, replacements and/or repairs but DO NOT modify the carrier. DO NOT use the unit if adjustments and/or repairs are incomplete!

An "adjustment" is a simple correction that restores the unit to satisfactory condition, such as tightening loose fasteners, or removing dirt or other debris from the surface. "Repair" refers to removing worn parts and installing manufacturer-approved replacement parts.

A "modification" is a change that alters the drum carrier from satisfactory condition, like bending the structural members or removing a part or several parts. **NEVER** modify the unit without the express, written approval of Vestil. Modifications might make the device unsafe to use and *automatically* void the LIMITED WARRANTY.

**Step 5:** Make a dated record of all repairs, adjustments and/or replacements.

# LABELING DIAGRAM

The unit should be labeled as shown in the diagram. However, label content and location are subject to change so your product might not be labeled exactly as shown. Compare this diagram to your [RECORD OF SATISFACTORY CONDITION](#). Replace all labels that are damaged, missing, or not easily readable (e.g. faded). Order replacement labels by contacting the [REPLACEMENT PARTS DEPARTMENT](#) online at <https://www.vestil.com/page-parts-request.php>. Alternatively, you may request replacement parts and/or service by calling (260) 665-7586 and asking the operator to connect you to the Parts Department.

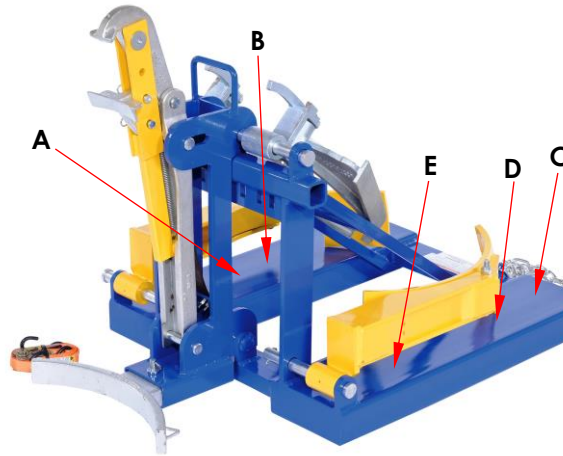

**A: Label 485**

⚠ CAUTION	⚠ PRECAUCIÓN	⚠ ATTENTION
When transporting hazardous waste or traveling in rough surfaces, use the supplied safety retaining strap	Precaución cuando transporte deshecho peligroso o cuando viaje por superficies irregulares, use el cinturón seguridad suministrado	Pour le transport de déchets dangereux ou pour circuler sur les voies non uniformes, utilisez la sangle de sécurité fournie
		485 rev 10/06

**B: Label 218 (on fork pocket)**

⚠ WARNING	⚠ ADVERTENCIAS
Improper use might result in death or serious personal injury. Attach device to fork carriage with safety chain/strap. <ul style="list-style-type: none"> <li>• Drive lift truck forward until forks contact ends of fork pockets</li> <li>• Chain/straps must not be able to disconnect (slide free) from carriage.</li> <li>• Safety chain/strap must be taut. Connect chain/strap to carriage via shortest line.</li> </ul>	El uso impropio puede resultar en muerte o heridas personales. Atar aparato al mástil del montacargas con cadenas/correas. <ul style="list-style-type: none"> <li>• Maneje el montacargas para adelante hasta que las cuñas hagan contacto con la orilla del bolsillo de las cuñas.</li> <li>• La cadenas y correas no deben de deslizar (soltarse) del mástil del montacargas.</li> <li>• La cadena/correa de seguridad debe de estar apretado. Asegure la cadena/correa al mástil via la ruta mas corta.</li> </ul>
	218 rev/0910

**D: Label 1049 (on fork pocket)**

⚠ WARNING
Improper use of this fork attachment might result in death or serious injury. <ul style="list-style-type: none"> <li>• Using this front end attachment affects lift truck center of gravity.</li> <li>• Before using this fork attachment, US Federal regulation 29 CFR 1910.178 requires you to contact the manufacturer of your lift truck and request:                             <ol style="list-style-type: none"> <li>1. Written approval [29 CFR 1910.178(a)(4)]</li> <li>2. Markings for (fork) lift truck that:                                     <ul style="list-style-type: none"> <li>- Identify the attachment;</li> <li>- Give approximate weight of truck and attachment at maximum elevation with laterally-centered load. [29 CFR 1910.178(a)(5)].</li> </ul> </li> </ol> </li> <li>• <b>DO NOT</b> use <b>UNTIL</b> lift truck is marked with corrected capacity tags.</li> </ul>
1049 rev 1118

**C: Label 1153 (on fork pocket)**

MODEL / MODÉLO / MODÈLE _____
WEIGHT / PESO / MASS _____
CAPACITY / CAPACIDAD / CAPACITÉ _____
SERIAL / SERIE / SÉRIE _____
UNITS: 2.2 lb. = 1kg      1" (or 1in.) = 2.54cm <b>1153</b>

**E: Label 1210 warning not to use with telehandlers**

⚠ WARNING
Using this front end attachment exposes occupants & bystanders to risks of serious personal injuries or death. <ul style="list-style-type: none"> <li>• <b>DO NOT</b> use this front end attachment with rough terrain lift trucks or telehandlers (boom lifts). <b>ONLY</b> use this attachment with high lift fork trucks utilizing a vertical mast and carriage.</li> <li>• <b>DO NOT</b> operate truck with attachment on unimproved surfaces. <b>ONLY</b> operate the truck with the attachment on concrete or asphalt surfaces capable of supporting the truck and a full capacity load.</li> </ul>

## OPTIONAL EQUIPMENT

Cushioned drum cradles are available for FMDL-style drum lifters. Models FMDL-1-LDS-B1 and FMDL-2-LDS-B1 include saddles equipped with rubber belts. FMDL-1-LDS-R3 and FMDL-2-LDS-R3 provide rollers along the face of the drum saddle. Exploded views of cushioned models are provided on pages 15, 16, and 17.

### FMDL-1-LDS-B1 (40-006-101)

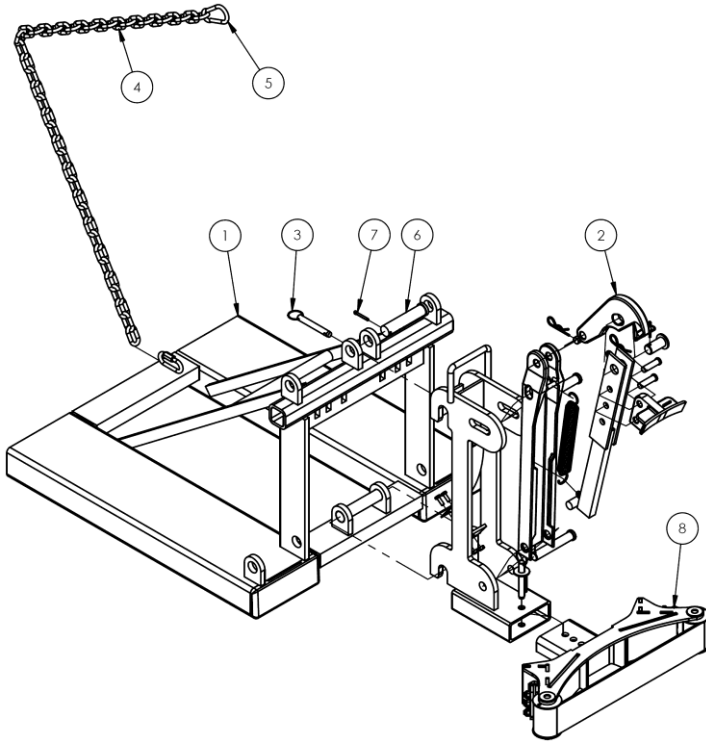

Item	Part no.	Description	Qty.
1	40-514-008	Weldment, frame	1
2	40-514-105	Frame, subassembly	1
3	99-112-004	Pin, self-locking, quick release	1
4	09-145-018	Chain, 5/16" x 56"	1
5	08-145-041	Snap hook, 5/16"	1
6	33-112-023	Pin, clevis	1
7	65125	Cotter pin, z-plated, 3/16" x 1 1/2"	1
*8	40-001-098	Saddle/bumper belt assembly	1

\* [Bumper belt subassembly exploded view provided on p. 14.](#)

### FMDL-2-LDS-B1 (40-006-102)

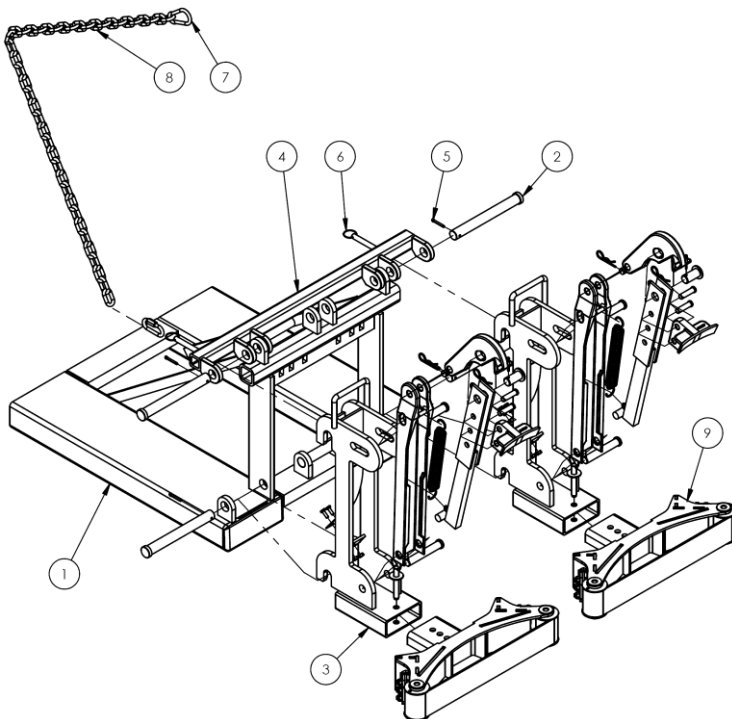

Item	Part no.	Description	Qty.
1	40-514-008	Weldment, frame	1
2	44-112-001	Pin, main, clevis	4
3	40-514-105	Frame, subassembly	2
4	40-516-008	Weldment, bracket, mounting bar	1
5	65125	Cotter pin, z-plated, 3/16" x 1 1/2"	1
6	99-112-004	Pin, self-locking, quick release	1
7	08-145-041	Snap hook, 5/16"	1
8	09-145-018	Chain, 5/16" x 56"	1
*9	40-001-098	Bumper belt subassembly	1

\* [Bumper belt subassembly exploded view provided on p. 14.](#)

### BUMPER BELT SUBASSEMBLY

(40-001-098 in [Exploded Views](#) on p. 13)

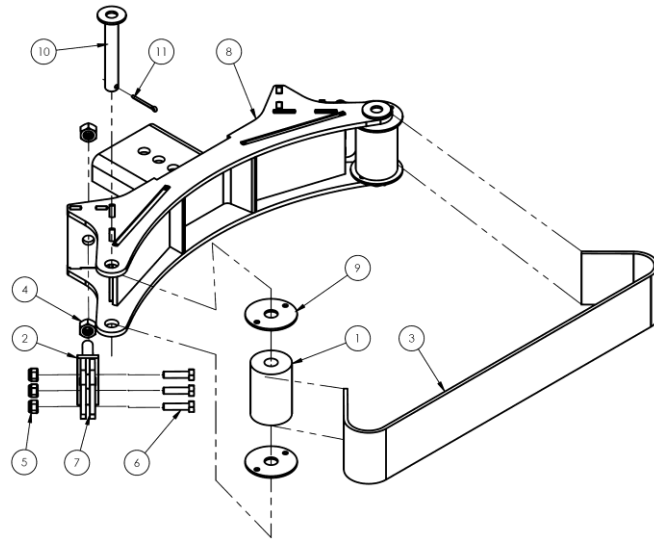

Item	Part no.	Description	Qty.	Item	Part no.	Description	Qty.
1	40-145-015	Roller, delrin	2	6	11057	Hex bolt, gr. A, zinc plated, 5/16"-18x 1 1/4"	6
2	40-516-023	Weldment, bracket, belt tensioner	2	7	40-016-136	Bracket, mount, belt clamp	2
3	40-145-013	Conveyor belt	1	8	40-514-103	Weldment, frame, belt	1
4	36110	Hex nut, z-plated, 1/2"-13	4	9	40-145-014	Roller washer	4
5	37021	Nylock nut, gr. 2, zinc finish, 5/16"-18	6	10	40-612-011	Weldment, pin, belt	2
				11	65078	Extended prong cotter pin, z-finish, 1/8"x1 1/2"	2

### DRUM SADDLE ROLLER SUBASSEMBLY

(40-001-097 in [Exploded Views](#) on p. 15)

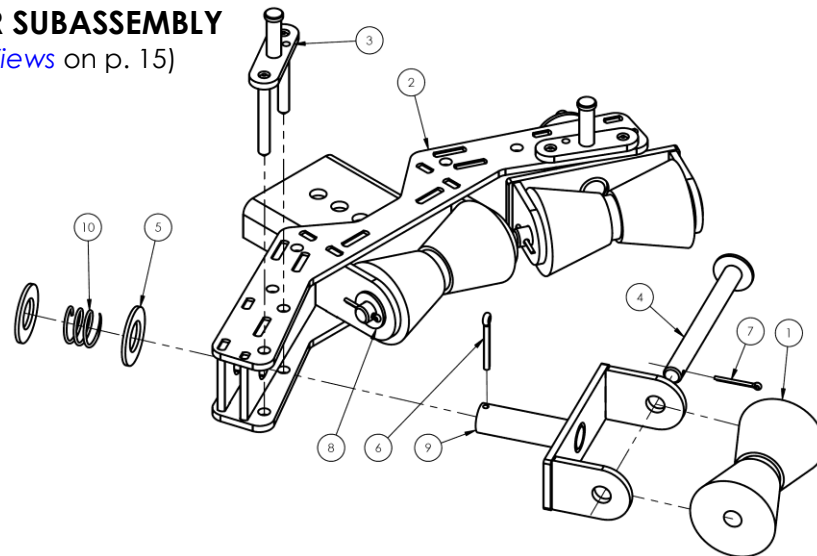

Item	Part no.	Description	Qty.	Item	Part no.	Description	Qty.
1	40-145-012	Roller, keel	3	6	65127	Cotter pin, zinc plated, 3/16" x 2"	2
2	40-514-102	Weldment, frame roller	1	7	65078	Extended prong cotter pin, z-finish, 1/8"x1 1/2"	3
3	40-613-001	Weldment, spacer, pin	2	8	33090	SAE flat washer, 5/8"	1
4	40-612-010	Weldment, pin, roller axle	3	9	40-514-104	Weldment, frame, bracket, roller mount	2
5	33095	SAE flat washer, 1 1/16" ID x 2" OD	4	10	40-146-006	Spring, compression	2



### FMDL-1-LDS-R3 (40-006-099)

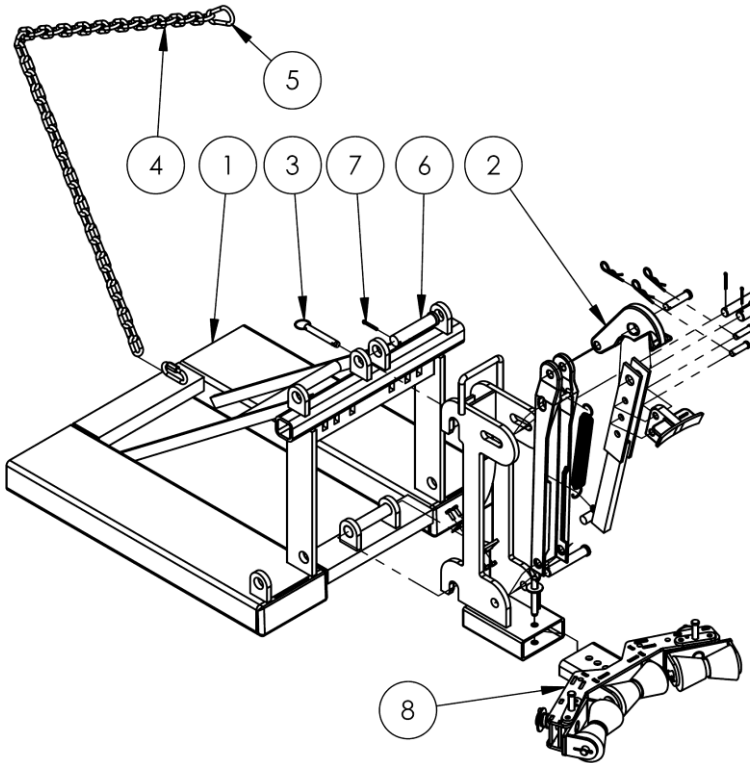

Item	Part no.	Description	Qty.
1	40-514-008	Weldment, frame	1
2	40-514-105	Frame, subassembly	1
3	99-112-004	Pin, self-locking, quick release	1
4	09-145-018	Chain, 5/16" x 56"	1
5	08-145-041	Snap hook, 5/16"	1
6	33-112-023	Pin, clevis	1
7	65125	Cotter pin, z plated, 3/16" x 1 1/2"	1
*8	40-001-097	Drum saddle roller subassembly	1

\* [Roller subassembly Exploded View provided on p. 14.](#)

### FMDL-2-LDS-R3 (40-006-100)

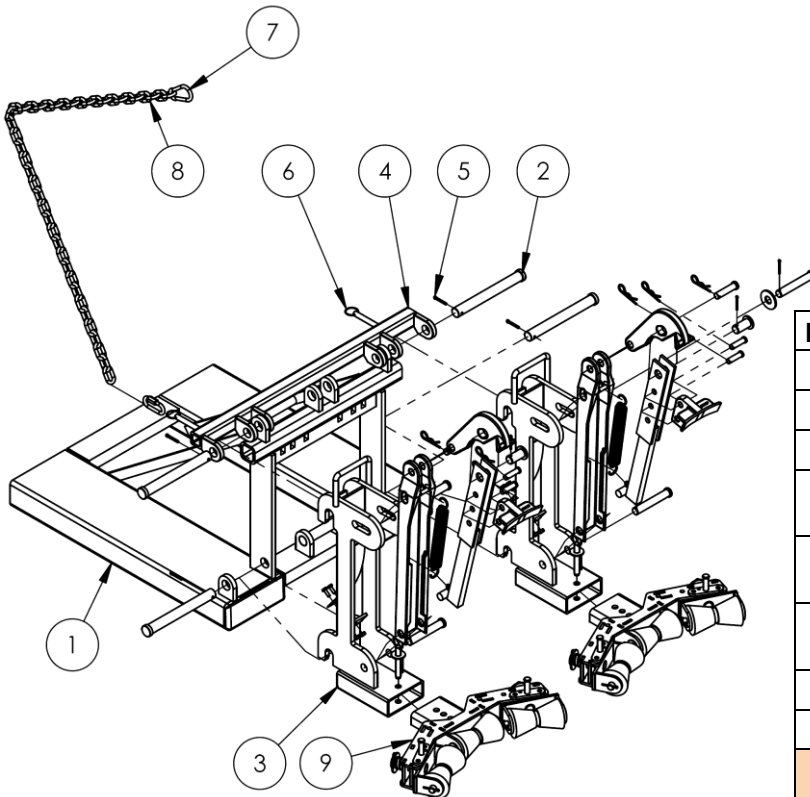

Item	Part no.	Description	Qty.
1	40-514-008	Weldment, frame	1
2	40-112-001	Pin, clevis	4
3	40-514-105	Frame, subassembly	2
4	40-516-008	Weldment, bracket, mounting bar	1
5	65125	Cotter pin, z plated, 3/16" x 1 1/2"	4
6	99-112-004	Pin, self-locking, quick release	2
7	08-145-041	Snap hook, 5/16"	1
8	09-145-018	Chain, 5/16" x 56"	1
*9	40-001-097	Drum saddle roller subassembly	2

\* [Roller subassembly Exploded View provided on p. 14.](#)

### FMDL-1-LDS-B1 DIMENSIONS AND CENTERS OF GRAVITY (40-007-101)

Net weight:  
304 lb.  
(138.2kg)

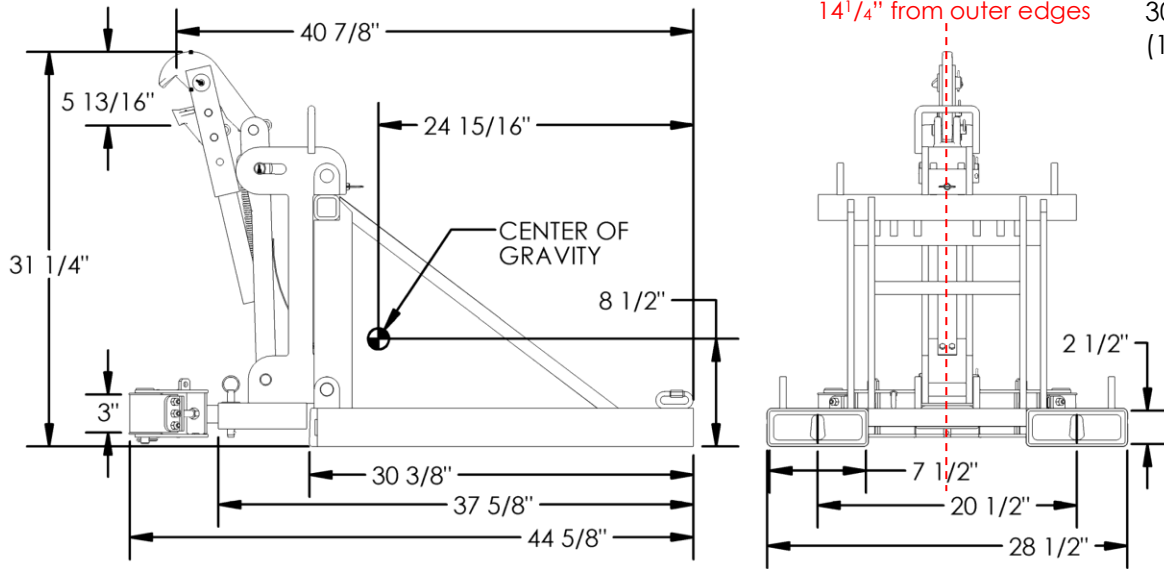

Horizontal center of gravity (HCG): 24<sup>15</sup>/<sub>16</sub> inches (~63.3cm) from the open ends of the fork pockets (middle graphic above) and 14<sup>1</sup>/<sub>4</sub> inches from the outermost edges of the fork pockets (dotted line in first graphic above).

Vertical center of gravity: 8<sup>1</sup>/<sub>2</sub> inches (~21.6 cm) from the top of the fork pockets.

**NOTE:** In order for the Eagle Beak™ mechanism to work properly, the drum and its contents must weigh AT LEAST 50 lb. (~22.7kg).

### FMDL-2-LDS-B1 DIMENSIONS AND CENTERS OF GRAVITY

Net weight:  
295 lb.  
(134.1kg)

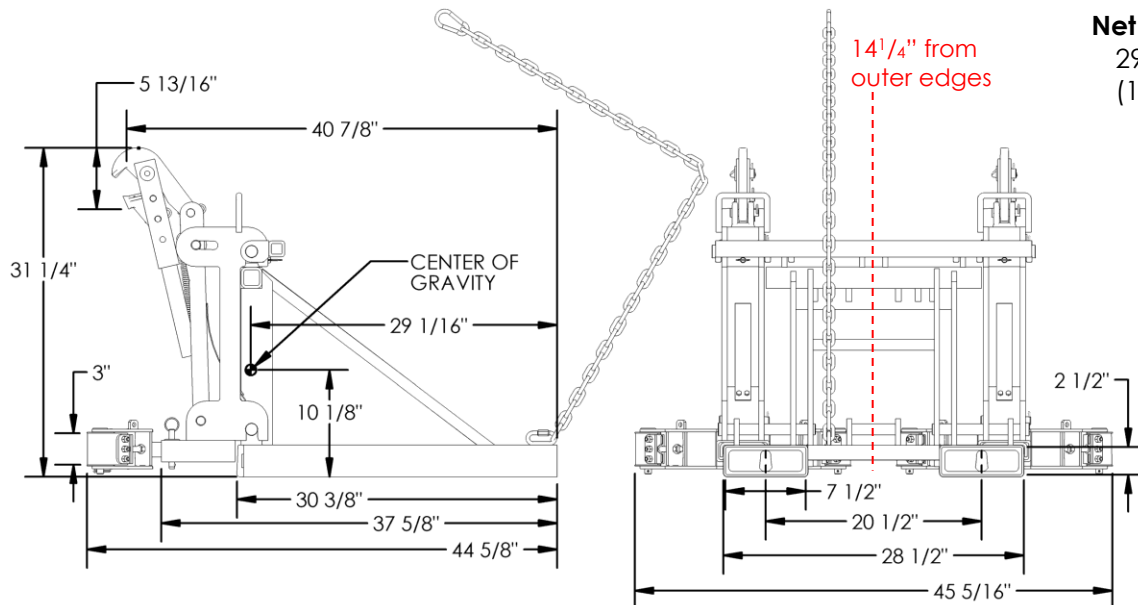

Horizontal center of gravity (HCG): 29<sup>1</sup>/<sub>16</sub> inches (~73.8 cm) from the open ends of the fork pockets (middle graphic above) and 14<sup>1</sup>/<sub>4</sub> inches from the outermost edges of the fork pockets (dotted line in first graphic above).

Vertical center of gravity: 10<sup>1</sup>/<sub>8</sub> inches (~25.7 cm) from the top of the fork pockets.

**NOTE:** In order for the Eagle Beak™ mechanism to work properly, the drum and its contents must weigh AT LEAST 50 lb. (~22.7kg).

### FMDL-1-LDS-R3 DIMENSIONS AND CENTERS OF GRAVITY (40-007-099)

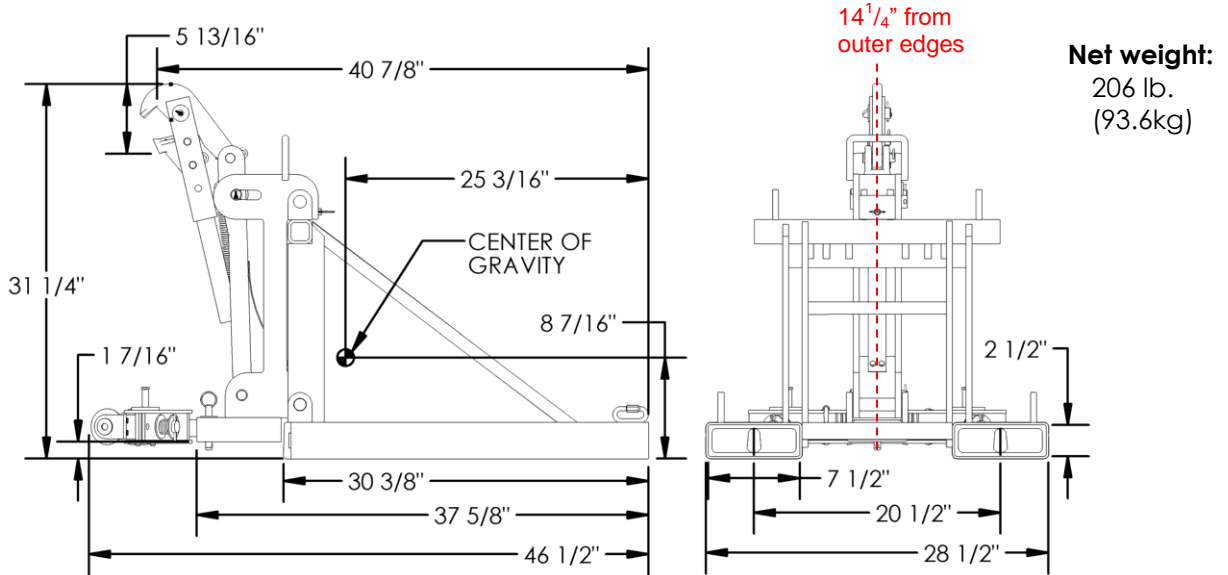

Horizontal center of gravity (HCG): 25<sup>3</sup>/<sub>16</sub> inches (~64.0 cm) from the open ends of the fork pockets (middle graphic above) and 14<sup>1</sup>/<sub>4</sub> inches from the outermost edges of the fork pockets (dotted line in first graphic above).

Vertical center of gravity: 8<sup>1</sup>/<sub>2</sub> inches (~21.4 cm) from the top of the fork pockets.

**NOTE:** In order for the Eagle Beak™ mechanism to work properly, the drum and its contents must weigh AT LEAST 50 lb. (~22.7kg).

### FMDL-2-LDS-R3 DIMENSIONS AND CENTERS OF GRAVITY (40-007-100)

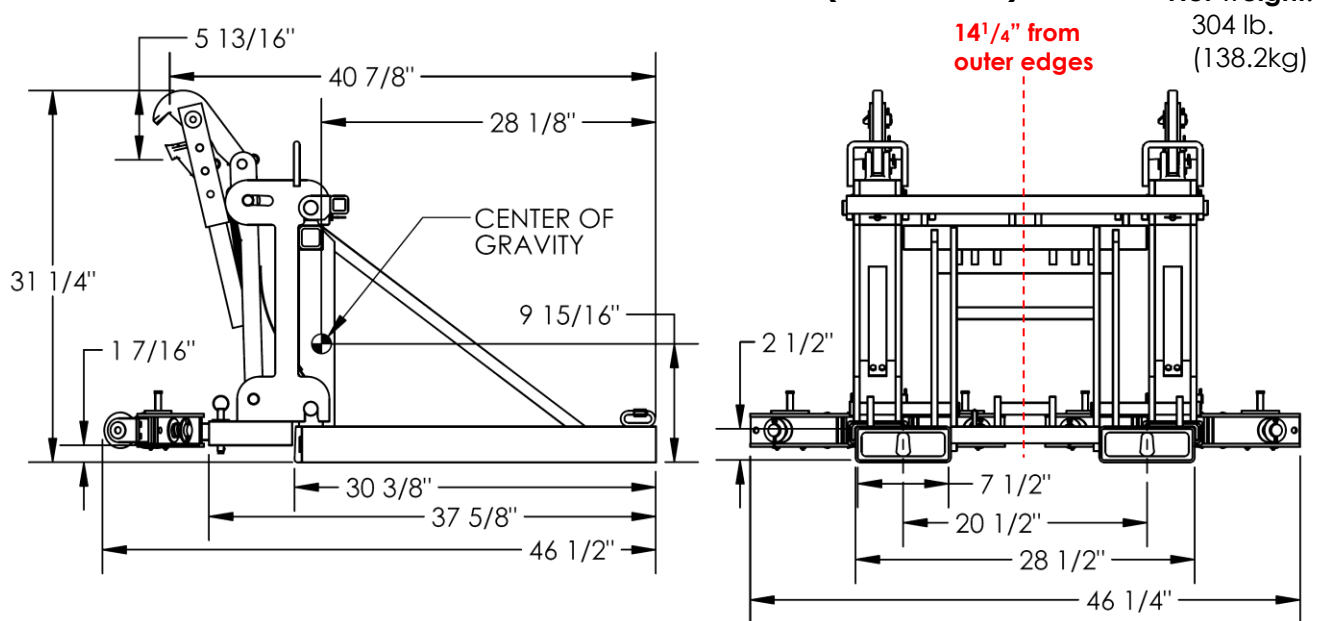

Horizontal center of gravity (HCG): 28<sup>1</sup>/<sub>8</sub> inches (~71.4 cm) from the open ends of the fork pockets (middle graphic above) and 14<sup>1</sup>/<sub>4</sub> inches from the outermost edges of the fork pockets (dotted line in first graphic above).

Vertical center of gravity: 9<sup>15</sup>/<sub>16</sub> inches (~25.2 cm) from the top of the fork pockets.

**NOTE:** In order for the Eagle Beak™ mechanism to work properly, the drum and its contents must weigh AT LEAST 50 lb. (~22.7kg).

## LIMITED WARRANTY

Vestil Manufacturing Company ("Vestil") warrants this product to be free of defects in material and workmanship during the warranty period. Our warranty obligation is to provide a replacement for a defective, original part covered by the warranty after we receive a proper request from the Warrantee (you) for warranty service.

### Who may request service?

Only a warrantee may request service. You are a warrantee if you purchased the product from Vestil or from an authorized distributor AND Vestil has been fully paid.

### Definition of "original part"?

An original part is a part used to make the product as shipped to the Warrantee.

### What is a "proper request"?

A request for warranty service is proper if Vestil receives: 1) a photocopy of the Customer Invoice that displays the shipping date; AND 2) a written request for warranty service including your name and phone number. Send requests by one of the following methods:

<u>US Mail</u>	<u>Fax</u>	<u>Email</u>
Vestil Manufacturing Company 2999 North Wayne Street, PO Box 507 Angola, IN 46703	(260) 665-1339 <u>Phone</u> (260) 665-7586	<a href="mailto:info@vestil.com">info@vestil.com</a> Enter "Warranty service request" in the subject field.

In the written request, list the parts believed to be defective and include the address where replacements should be delivered. After Vestil receives your request for warranty service, an authorized representative will contact you to determine whether your claim is covered by the warranty. Before providing warranty service, Vestil will require you to send the entire product, or just the defective part (or parts), to its facility in Angola, IN.

### What is covered under the warranty?

The warranty covers defects in the following original, dynamic parts: motors, hydraulic pumps, motor controllers, and cylinders. It also covers defects in original parts that wear under normal usage conditions ("wearing parts"), such as bearings, hoses, wheels, seals, brushes, and batteries.

### How long is the warranty period?

The warranty period for original dynamic components is 90 days. For wearing parts, the warranty period is 90 days. Both warranty periods begin on the date Vestil ships the product to the Warrantee. If the product was purchased from an authorized distributor, the periods begin when the distributor ships the product. Vestil may, at its sole discretion, extend a warranty period for products shipped from authorized distributors by up to 30 days to account for shipping time.

### If a defective part is covered by the warranty, what will Vestil do to correct the problem?

Vestil will provide an appropriate replacement for any covered part. An authorized representative of Vestil will contact you to discuss your claim.

### What is not covered by the warranty?

The Warrantee (you) is responsible for paying labor costs and freight costs to return the product to Vestil for warranty service.

### Events that automatically void this Limited Warranty.

- Misuse;
- Negligent assembly, installation, operation or repair;
- Installation/use in corrosive environments;
- Inadequate or improper maintenance;
- Damage sustained during shipping;
- Collisions or other accidents that damage the product;
- Unauthorized modifications: Do not modify the product IN ANY WAY without first receiving written authorization from Vestil.

### Do any other warranties apply to the product?

Vestil Manufacturing Co. makes no other express warranties. All implied warranties are disclaimed to the extent allowed by law. Any implied warranty not disclaimed is limited in scope to the terms of this Limited Warranty. Vestil makes no warranty or representation that this product complies with any state or local design, performance, or safety code or standard. Noncompliance with any such code or standard is not a defect in material or workmanship.

